

## N7 Captive Nut

Thru hole and blind styles

### Features

- Spring ejected
- Knurled knob provides solid grip
- Fastens to externally threaded studs
- Helps speed panel replacement

### Material

- Knob: Aluminum, natural
- Ferrule: Hardened steel, zinc plate, chromate plus sealer
- Spring: 302 Stainless steel, passivated

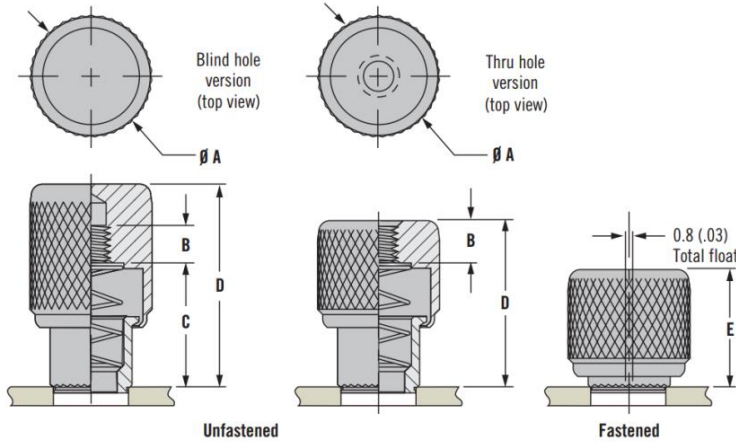

**Notes:** For use in material hardnesses RB85 or less, such as low carbon steels that are half hard or softer, stainless steels in the annealed condition and aluminum.

### Installation Notes

1. Prepare hole in panel as shown
2. Provide a solid back-up surface behind the panel
3. Press the assembly into the panel until only the top of the knurl on the ferrule is visible

### Threadstud insert selection for blind hole applications

- Frame thickness + panel thickness + P  
Minimum = X Minimum
- Frame thickness + panel thickness + P  
Maximum = X Maximum
- Threadstud insert length (L): X Minimum < "L" > X Maximum
- "L" values greater than X Maximum must use the thru hole version
- If a weld stud is used, omit the frame thickness from the calculations (see the table and diagram to the right)
- \*The above dimensions are for blind hole captive nuts

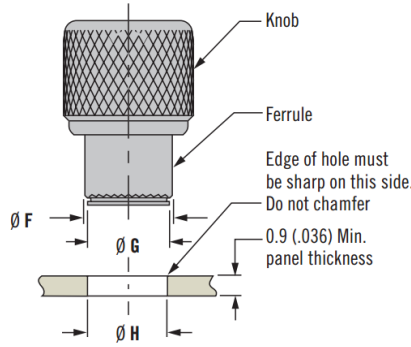
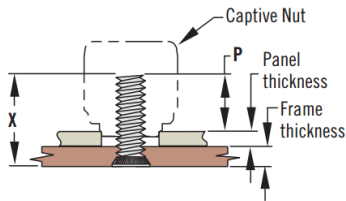

**Notes:** Recommended minimum distance from edge of panel to centerline of hole is 1.5 x Ø H.

Thread Size	P Min.	P Max.
M3	7.1 (.28)	9.5 (.37)
M4	10 (.40)	12.1 (.47)
M5	10.2 (.41)	12.2 (.48)
M6	12.4 (.49)	16.7 (.66)
4-40	7.3 (.29)	9.4 (.37)
6-32	9.9 (.39)	13.1 (.51)
8-32	10.1 (.40)	13.3 (.52)
10-32	10.3 (.41)	13.5 (.53)
1/4-20	13 (.51)	16.5 (.65)

Thread Size	Knob Style	Part Number		Ø A	B (Thread Length)	C	D	E	Ø F	Ø G	Ø H
		Metric	Inch								
M3 or 4-40	Thru hole	N7-02-10	N7-52-10	10.6 (.42)	3.6 (.14)	~	12.8 (.50)	9.3 (.37)	6.4 (.25)	5.5 (.22)	5.6±0.04 (.220±.002)
	Blind hole	N7-02-11	N7-52-11		4 (.16)	9.2 (.36)	16.8 (.66)	13.3 (.52)			
6-32 UNC	Thru hole	~	N7-62-10	11.4 (.45)	4.7 (.19)	~	17.7 (.70)	12.5 (.49)	7.1 (.28)	6.3 (.25)	6.4 <sup>+0.03</sup> <sub>-0.05</sub> (.252 <sup>+0.001</sup> <sub>-0.02</sub> )
	Blind hole	~	N7-62-11		5.4 (.21)	13 (.51)	23 (.91)	17.9 (.70)			
M4 or 8-32	Thru hole	N7-22-10	N7-72-10	13 (.51)	4.5 (.180)	~	17.7 (.70)	12.5 (.49)	8.7 (.34)	7.9 (.31)	8 <sup>+0</sup> <sub>-0.08</sub> (.315 <sup>+0</sup> <sub>-0.003</sub> )
	Blind hole	N7-22-11	N7-72-11		5.4 (.21)	13.2 (.52)	23 (.91)	17.9 (.70)			
M5 or 10-32	Thru hole	N7-32-10	N7-82-10	13 (.51)	4.5 (.180)	~	17.7 (.70)	12.5 (.49)	9 (.35)	7.9 (.31)	8 <sup>+0</sup> <sub>-0.08</sub> (.315 <sup>+0</sup> <sub>-0.003</sub> )
	Blind hole	N7-32-11	N7-82-11		5.4 (.21)	13.2 (.52)	23 (.91)	17.9 (.70)			
M6 or 1/4-20	Thru hole	N7-42-10	N7-92-10	14.6 (.58)	6.4 (.25)	~	22.8 (.90)	16 (.63)	10 (.39)	9.4 (.37)	9.5 <sup>+0.1</sup> <sub>-0</sub> (.374 <sup>+0.004</sup> <sub>-0</sub> )
	Blind hole	N7-42-11	N7-92-11		7 (.28)	16.4 (.65)	29.5 (1.16)	23 (.91)			

